

## Technical Data Sheet

# Aerosol Extinguishing Generator with Pneumatic Activation Dynameco 200 - PA01

**Intended purpose:**

Pyrotechnic aerosol fire extinguishing generator for use within pneumatic detection fire extinguishing systems

**Operation:**

A pyrotechnically formed aerosol extinguishing agent is released following activation of the connected pneumatic trip system

## Dynameco 200 - PA01

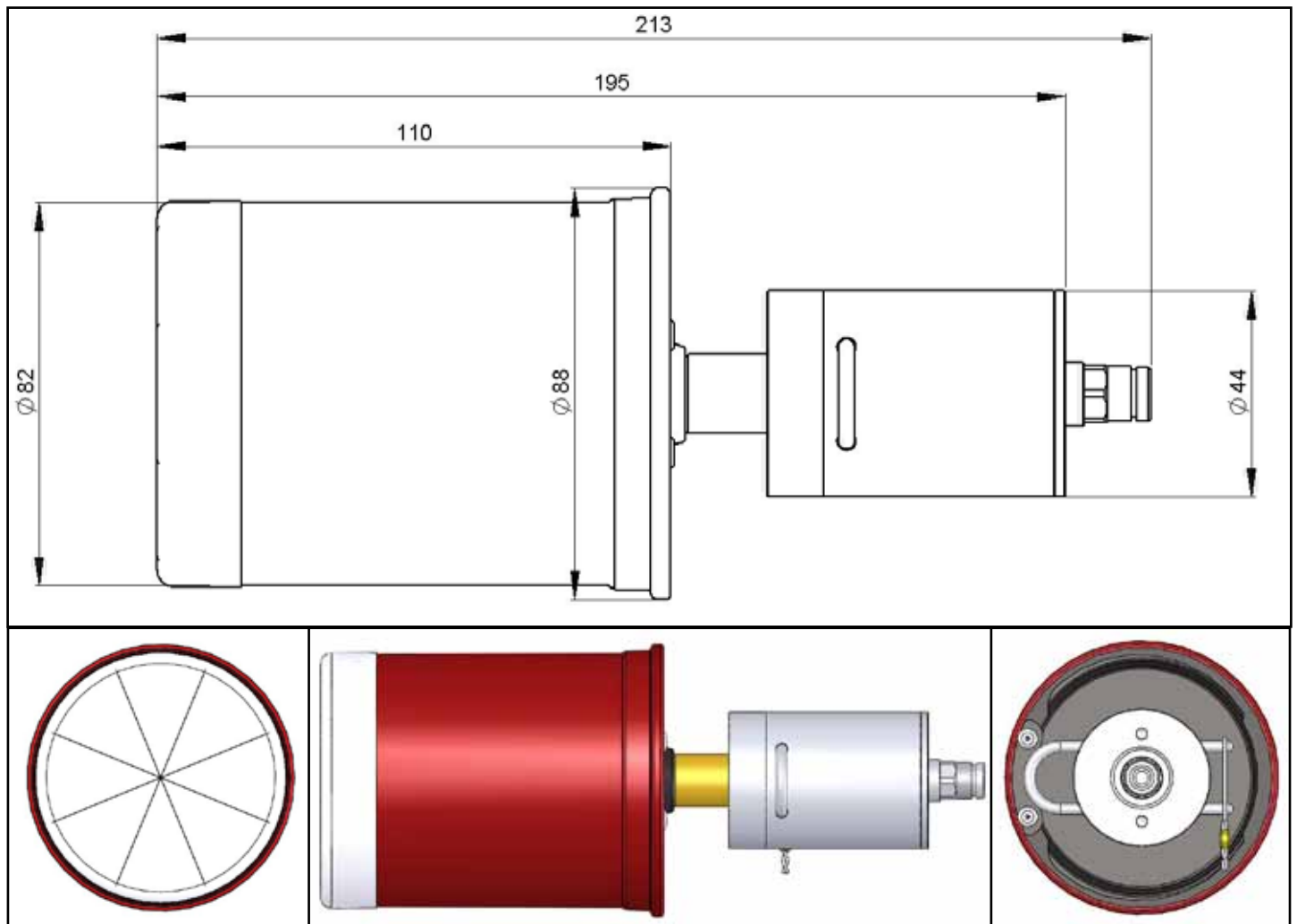

Further technical details provided on request.

The right is reserved to make technical changes without notification.

Date: April 2010

## Dynameco 200 - PA01

### TYPE-SPECIFIC DATA

Dimensions:	H = 110 / 213 mm (with/without trigger) D = 82 mm
Weight, complete:	approx. 1,17kg
AEROSOL generation time:	approx. 5 secs
Room volume to be protected:	2,0 m <sup>3</sup>

### SYSTEM-SPECIFIC DATA

Sensor hose to be used:	FiWaGuard-Sensor hose-HR (black) Internal diameter: 4mm; External diameter: 6mm
System pressure:	nominal: 15 bars maximum: 20 bars
Start of effect:	immediately after activation of pneumatic trip system
Storage:	Cool and dry
Generator operating temperature:	-40°C to max. 85°C
Approval mark:	PL-4/ 97 / Aerosol extinguishing agent
Fire class:	B (limited) und C on DIN EN2

### APPLICATION-SPECIFIC DATA

Durability:	5 years
Note:	All product-specific instructions for use and installation must be observed