

**Activator Dynameco**



Registry Number: 0589-P1-000117  
 ID-Number: BAM-P1-0075

Dear Customer,

By purchasing a Dynameco aerosol extinguisher generator with a thermal activator you have acquired a quality product.



**Important:**  
 Please take careful note of the following important instructions which concern your safety and the operational safety of the aerosol extinguisher generator with a thermal activator.

Please read these instructions for use completely before you remove the aerosol extinguisher generator with thermal activator from the packaging and assemble and activate it on its installation point.

As delivered, the aerosol extinguisher generator with thermal activator comes deactivated from the factory (see point 6 of the instructions for use).

After you have removed it from the packaging, please check that the aerosol extinguisher generator (component drawing no.5) and the glass ampule (component drawing no. 2) in the thermal activator (component drawing no.1) are undamaged.

**Instructions for use**

1. Mode of operation of the aerosol extinguisher with thermal activator
2. Areas of use
3. Storage
4. Assembly
5. Activating the thermal activator
6. Deactivating the thermal activator
7. Removal
8. Periodical inspection of the aerosol extinguisher with thermal activator
9. Instructions for the exclusion of misuse
10. Disposal
11. Age restriction

**1. Mode of operation of the aerosol extinguisher with thermal activator**

The effect of this fire extinguisher system is based on producing an aerosol with the extinguishing substance potassium carbonate via the burning off of a propellant charge.

This aerosol is thereby suited to extinguishing the flames of a fire.

In the extinguishing process energy is withdrawn from the flame. In this process the atmospheric oxygen remains.



**Important:**  
 Fighting a fire must be done in its early phases since the extinguishing substance has no cooling effect on the objects which ignited and otherwise, as a result of their high surface temperature, they could be reignited after the flame has been extinguished.

To fight a fire in its early phases the correct activation temperature for the thermal activator must be selected (see point 2 in the instructions for use).When extinguishing an object the aerosol stream should be directed straight into the flame.

If there is room flooding attention must be paid to the correct concentration of the extinguishing substance.



**Caution:**  
 The aerosol extinguishing substance stream is hot.



**Do not touch the aerosol extinguisher generator after use as there is a danger of being burnt!**

After the aerosol extinguisher generator has been triggered it can be that visibility is considerably reduced. There are certain technical measures which can be taken if necessary to reduce this effect.

**2. Areas of use**

The use of an aerosol extinguisher generator with thermal activator is allowed if there is no fire alarm system. In this case the trigger temperature of the thermal activator must be set so that the fire fighting is done during the time when the fire first starts.

Aerosol extinguisher generators with thermal activator are available with the following trigger temperatures: 57°C (orange glass bulb), 68°C (red glass bulb), 79°C (yellow glass bulb), 93°C (green glass bulb).

If you are not sure we recommend talking to the respective distributor's user advice centre.

**3. Storage**

The aerosol extinguisher generator with thermal activator is stored in the packaging in which it is delivered. A cool and dry storage place must be provided.

The storage temperature must not go below -40°C and can be at the most 15°C below the stated trigger temperature of the thermal activator.

Trigger temperature	Glass bulbs colour	Max. storage temperature
57°C	orange	42°C
68°C	red	53°C
79°C	yellow	64°C
93°C	green	78°C

## 4. Assembly



### Important:

The place where the aerosol extinguisher generator with thermal activator is installed must meet the storage temperature requirements when being assembled and during operation. (see point 3 in the instructions for use)

Assembly and installation may only be carried out by trained personnel.

Here attention should be paid to the following points:

- The location of the aerosol extinguisher generator should be selected so that people and heat-sensitive objects would not be directly in the aerosol stream or would be protected from it.

For people and objects with no protection a minimum distance of 1.5m is required.

- The location of the aerosol extinguisher generator should be selected so that the thermal activator can be activated after assembly (see point 6 in the instructions for use) and can be deactivated before being removed (see point 6 in the instructions for use).
- Fix the aerosol extinguisher generator firmly into the mounting provided for it. The way the device is locked depends on how the mounting is constructed.



### Important:

When installing attention should be paid to the effective direction.

- Check that the aerosol extinguisher generator is correctly and firmly fitted.

## 5. Activating the thermal activator



### Important:

As delivered, the aerosol fire extinguisher generator with thermal activator comes deactivated from the factory

The thermal activator should only be activated when the assembly has been correctly carried out (see point 4 in the instructions for use). Please ensure that the glass bulb (see component drawing no. 2) is not damaged. Keep the safety hexagonal socket screws (see component drawing no. 3) protected after activation for a later deactivation.

When **activating** attention should be paid to the following points:

- The aerosol extinguisher generator with thermal activator has been correctly assembled.
- The requirements concerning storage temperature have been fulfilled (see point 3 in the instructions for use).
- The two safety hexagonal socket screws ISO 4762- M3x12 (see component drawing no. 3) must be turned completely to the left in the direction of rotation (see component drawing no. 3.1), and removed from the pressure plate (see component drawing no. 4) on the thermal activator.



In case of uncontrolled triggering the erasing procedure can not stop.



### Important:

After point c) has been concluded the aerosol extinguisher generator is activated and ready for operation.

### Thermal activator: activated



### activation process



## 6. Deactivating the thermal activator



### Important:

The requirements concerning storage temperature have been fulfilled (see point 3 in the instructions for use).

The glass bulb (see component drawing no. 2) in the thermal activator (see component drawing no. 1) is not damaged.

When **deactivating** attention should be paid to the following points:

- The correct safety hexagonal socket screws ISO 4762- M3x12 (see component drawing no. 3) are ready for use
- turn the safety hexagonal socket screws to the right in the direction of rotation (see component drawing no. 3.2) until there is a slight catch on the screw heads (with a torque of 0.03 – 0.05Nm) on the pressure plate (see component drawing no. 4) of the thermal activator.



### Important:

After point b) has been concluded the aerosol extinguisher generator with thermal activator is deactivated and no longer ready for operation.

### Thermal activator: deactivated



### deactivation process



## 7. Removal



### Important:



**After the extinguishing process the aerosol extinguisher generators are very hot. Danger of burns!**

After the extinguishing process, leave the aerosol extinguisher generator (see component drawing no. 5) to cool down. If removal is necessary immediately after the extinguishing process, suitable tools and protective materials should be used.

If the aerosol extinguisher generator is to be removed without having extinguished anything previously, the thermal activator must be deactivated (see point 6 in the instructions for use).

For **disassembly**:

- a) The mechanical lock on the mounting of the aerosol extinguisher generator must be released.
- b) The aerosol extinguisher generator must be taken out of the mounting.



### Important:

Further use of the functionally prepared aerosol extinguisher generator with thermal activator is possible after it has been activated once again.

## 8. Periodical inspections of the aerosol extinguisher with thermal activator

Depending on its installation and the external conditions, regular visual inspections of the aerosol extinguisher generator with thermal activator should be made to check for external integrity.

The time intervals between inspections must be suited to the installation requirements and the resulting demands. If the aerosol extinguisher generators with thermal activator are installed in a location where they undergo particular stresses and strains, e.g. vibration, large temperature variations or heavy pollution, it is recommended to carry out a weekly inspection. In normal cases an inspection of the aerosol extinguisher generator should be carried out every three months

For the inspection, particular attention should be paid to the following points:

- a) There should be no external damage exhibited on the thermal activator (see component drawing no. 1) and especially the glass bulb (see component drawing no. 2) in the thermal activator. In the case of damage the aerosol extinguisher generator with thermal activator must be exchanged.
- b) For transportation the fire extinguisher must be deactivated before.
- c) There should be no external damage such as dents or similar exhibited on the aerosol extinguisher generator (see component drawing no.5). In the case of damage the aerosol extinguisher generator with thermal activator must be exchanged.

- d) The metal foil which seals the aerosol extinguisher generator on the extinguisher recess side (see component drawing no. 6) must be undamaged and may not exhibit any excessive staining from paint or varnish or similar substances which could prevent the metal foil from bursting when the extinguisher is needed. In this case the aerosol extinguisher generator must be exchanged or the contaminant must be removed from the foil.



### Caution:

The metal foil must not be damaged during this.

- e) The aerosol extinguisher generator must be firmly fitted into the mounting provided for it.



### Important:

The maximum length of operation of 5 years from the date of manufacture must not be exceeded.

## 9. Instructions for the exclusion of misuse



### Important:

The aerosol extinguisher generator may only be stored in the packaging provided. Removal from the packaging should only be done if it is to be assembled.

The required storage conditions with respect to temperature must be kept to.

For assembly only externally undamaged aerosol extinguisher generators may be used. Damaged aerosol extinguisher generators must be returned to the manufacturer.

Aerosol extinguisher generators must under no circumstances be opened. Any attempt to open it mechanically, to insert objects from outside into the aerosol extinguisher generator or the use of mechanical power from the outside on the aerosol extinguisher generator is forbidden.

The aerosol extinguisher generators should be kept away from any kind of permanent exposure to warmth (open fires, heater fans, radiant heaters). Attention must be paid to the maximum storage and operational temperatures.

Attention must be paid to the safety data sheets and the cleaning recommendation.

### Disposal

Once activated, Dynameco aerosol extinguishing generators can be disposed of with the household waste.



### Caution:

**Under no circumstances should aerosol extinguishing generators be disposed of with household waste without previous activation.**

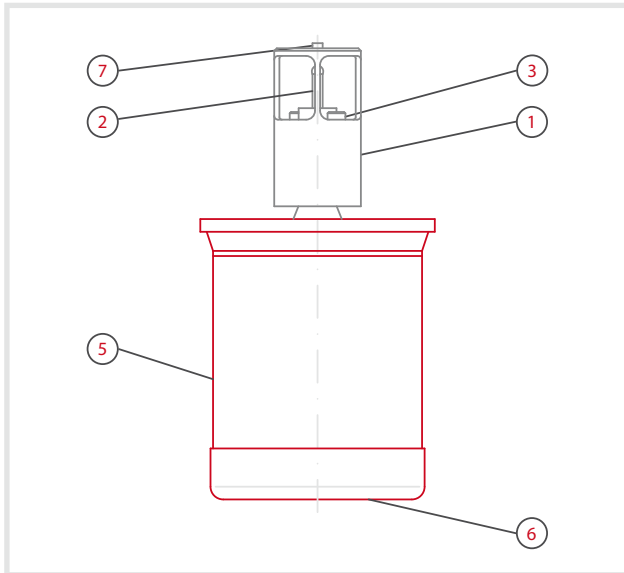

Drawing 1

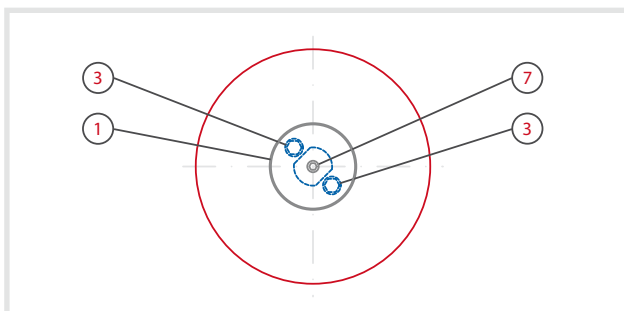

Drawing 2

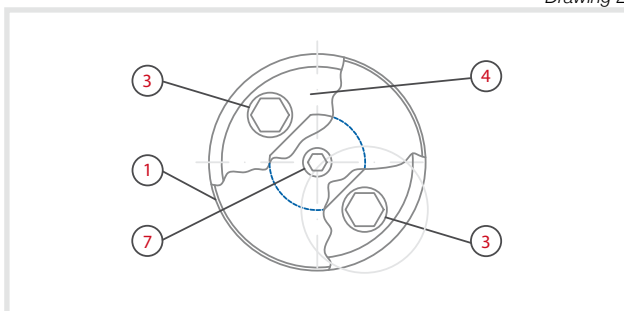

Drawing 3

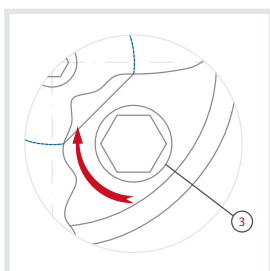

Drawing 3.1

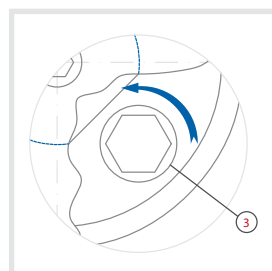

Drawing 3.2

Extinguishing generators in working order which need to be disposed of due to age or damage must be returned to the manufacturer.

**Caution:**



**Aerosol extinguishing generators in the Dynameco-TA08 series are not intended to be disposed of by the customer.**

**10. Age restriction**

**Important:**



Dynameco extinguishing generators may only be handled by trained persons of more than 18 years of age. (In countries outside the European-Union differing legal provisions are possible.)

- ① Thermal activator
- ② Glass bulb
- ③ Hexagonal socket screw
- ④ Pressure plate
- ⑤ Extinguishing generator
- ⑥ Discharge side
- ⑦ Fixing screw



**Important:**  
Don't change the screw for fixing the glass bulb.