

Instruction

Type: D, ZD, Z, H

UZS-801CD8S7

Thank you for choosing WRT. Please read this manual before using. WRT reserves the right to change specifications or designs described in this manual without notice and obligation.

WRT®

Content

WRT[®]

1.0 Features & Functions	1
2.0 Equipment Description	2
UZS-801CD8S7	2
3.0 Caution	3
4.0 Installation	4
5.0 Operation	5~27
6.0 Specification	28
7.0 Terminal Description	29
8.0 Trouble Shooting	30
9.0 Wiring	31

Content

801 intercom systems is composed by building gate station, user door phone, PC and other equipments, which is based on TCP/IP. The system is with the technology of multichannel, every channel can work independently.

1. Suit for large community
2. Wall-mounted installation, touch operation.
3. 7.0" LCD Display, monitor the situation at the entrances and confirm visitors again, remote unlock
4. Can call the Guard Center, and send the emergency to Guard Center.
5. Call the other tenant for intercom
6. Ring tone Download and Mute Mode
7. Function for lift
8. Divert
9. 8 alarm zones with arm/disarm function.
10. Wireless home automation control.
11. Check pictures, SMS etc.
12. Support the service for the convenience of the customers.
13. Parallel Operation is allowed, at most 4 Indoor Monitors can be work together
14. Remote update

UZS-801CD8S7

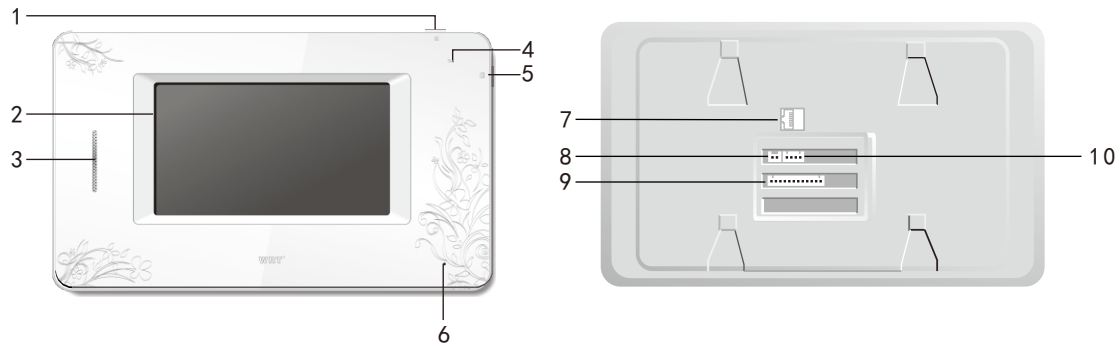

- 1.Alarm 2.Screen 3.Speaker 4. Lift 5. Status indicator light
6. Microphone 7. Network port 8. Socket for +18VDC input 9. Socket for Alarm sensor
10.Socket for External doorbell/ External alarm button

1. Do not install the stations in any of the location with waterdrop, high temperature and dust.
2. We suggest the installation height to be 145 cm above floor.
3. Be sure to cut off the power during installation.
4. Using wiring tube to avoid signal interference. Leave the terminals outside the tube for maintenance.
5. Make sure wires are connected properly before plugging in power supply.
6. When it is energized, cut off power at once if there is any problem.
7. If the system is found of any malfunction, please cut off the power and inspect according to the Trouble Shooting. If it is unable to find the causes, please contact the sales agent or the manufacturer's after-sales service department. Do not repair or replace the parts by yourself, otherwise the system may be damaged.

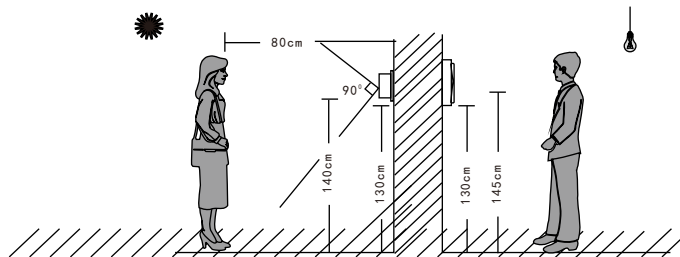

Installation

1. Make a hole at the height of 145cm and make sure it's fit for the bottom case. (Figure 1)
2. Open a wiring hole in the bottom of the wiring box an insert the wires through the wiring hole, and fix the bottom case into the hole ,embed cement.(Figure 2)

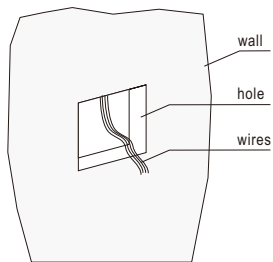

Figure 1

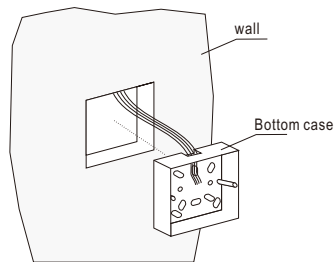

Figure 2

3. Fix the bracket on the bottom case with 2 screws.(Figure 3)
4. Connecting the wires,then hang the door phone on the bracket.(Figure 4)

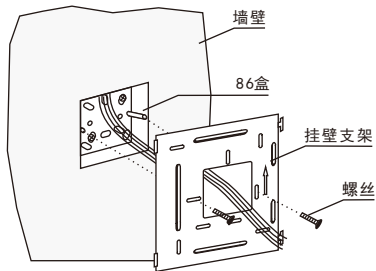

Figure 3

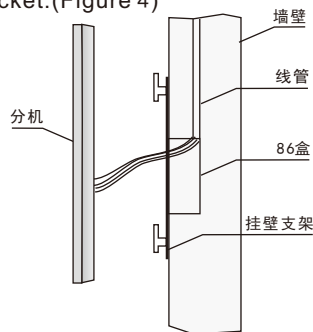
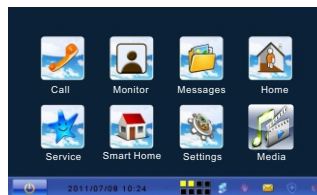

Figure 4

This door phone is operated by touching. It will boot normally after 30s when it is energized.

The status indicator light will become green when standby. Touch the screen when it is in standby state, and can operate it again.



There are 8 icons: Call, Monitor, Messages, Home, Service, Smart home, Settings, Media on homepage.

Touch  can turn off the screen, it will be in screen saver or shut down if there is no operation after 3 mins.

Settings

Specification of the door phone must be set after connected. Press “Settings” icon, turn to the interface where you can set password, room number, defence zone etc.

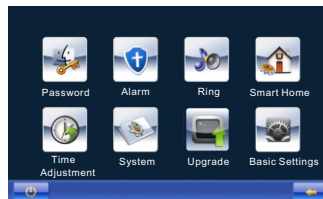

Password

Touch “Password” icon, and input the old password (input the PIN “88888888” for first usage), and press “#” key to confirm. If you forget the password, you can restore it to PIN through the Guard Center.

Operation

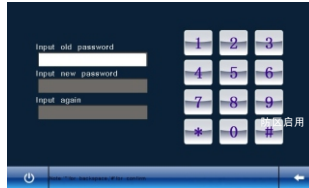

Alarm

There are two lines of indicator lights show on the behind of the main interface. Black means alarm zones disabled, green means unarm, yellow means armed, red means there is a alarm.

8 alarm zones in all, zones 1 to 4 represent fire, gas, IR and magnetic contact, 5 to 8 are user-defined.

You have to enable the alarm zones before configuring.

Touch the “Alarm” icon, input the password and press “#” to confirm.

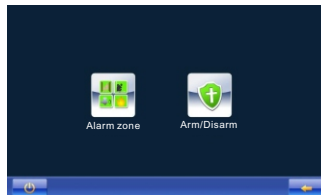

Touch “Alarm Zone” icon, click the zones to arm them and click ✓ to confirm, click the armed zones again to disarm them. Click ← to return to previous menu.

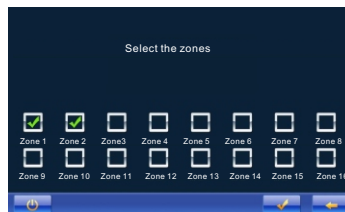

Arm/Disarm: it works only if it is “home” mode.

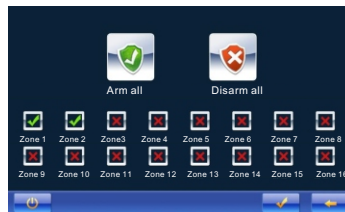

Click the alarm zone you need, and press ✓, if “Du Du” sound is heard, the alarm indicator lights will become yellow. Click armed zones and then click ✓ to disarm.

Arm all: Click “Arm all” and click ✓ to arm the enabled alarm zone.

Disarm all: Click “Disarm all” and click ✓ to disarm the armed zone.

Note: Smoke and Gas zones will be arming status as soon as enabled.

Ring

Set ring tones for entrance station, gate station, outdoor station, intercommunication indoor monitors, alarm, message etc. Click “Ring”

Operation

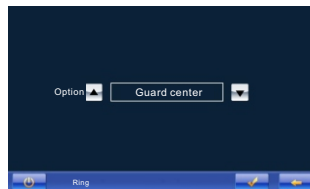

Select the call in locations via “▲” or “▼”, and press √ to confirm.

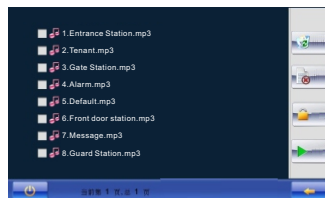

当前第1页，总1页：
Page 1, total 1

: Delete all ring tones (except the default ring tone and locked ring tone)

: Delete the selected ring tones ("√" means selected, the selected ring tone will be yellow)

 / : Lock/Unlock the selected ring tones, the selected ring tone can not be deleted)

: Play the selected ring tone.

 and : Turn the page when there are too many ring tones.

Smart Home---Set for the home automation function

The door phone can be used as control panel in RF wireless home automation system, but configure system first.

Touch "Home", input the password and press"# " key,

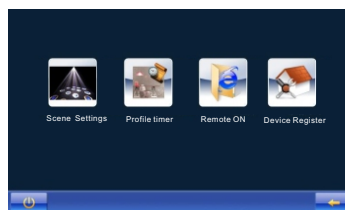

and touch "Device Register".



Operation

Gateway ID: Master station ID while setting Home system software

Register code: Control password while setting Home system software

Gateway IP: Destination IP address while setting Home system software

Room ID: ablet ID while setting Home system software.

Input correct parameters to entry boxes, and press “√” to confirm.

While input the parameters, press “*” to delete the former word , press “#” to input” . ”

Scene settings

Touch “Scene settings” :



For example, select “Guest”:



Select any mode you want(the selected one would be yellow), press “*” delete the information, press number key to input new scene NO..

When tenant input scene NO. which should be the same as scene NO. in scene mode while set

home system software. If tenant need to connect with arm zone, select it and select the zones which are enabled among the pop-up zone options:

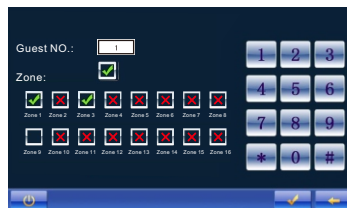

After completed, press “√” to confirm then zone arm will execute appropriate actions.

Profile timer : Set one scene for the time point of everyday(except weekend)

Click “Profile timer”,it will show:

时: h 分:m

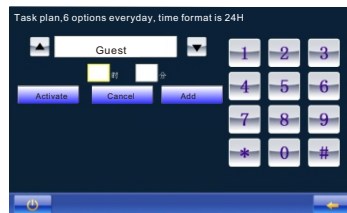

Press “▲” or “▼” to choose Scene Mode (Home ,Outside, Night light ,Get up, and User-defined mode), input activate time (click the entry box before hour/minute, it means selected when become yellow, then input the number), click ”Add” can add scene mode. Click”activate” can make the scene mode activate automatically on certain time everyday.

After click "activate", “activate” become “stop” , click “stop” can stop the scene mode.

Tenant can add several scene modes (≤6) at one time, then click “activate”.

Operation

Click “CancelAll” can eliminate all scene modes which are added.

Remote on: set if remote control home furnishing. Click “Remote on/Remote off”, open/close remote control.

When remote control is on, tenant can control home furnishing by Guard Center.

Time adjustment: Adjust time to keep in accordance with center unit.

System : Check IP address and functions current status.

Upgrade: Extended

Basic Setting

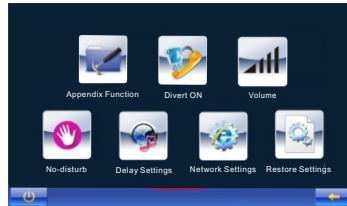

Click “Basic Setting” to set “Divert On” “Color” “Volume” etc.

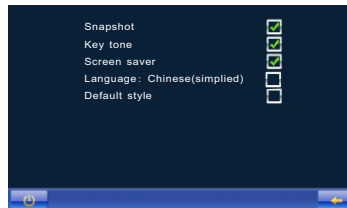

Appendix function: User can set snapshot, key tone, etc.



Operation

Touch the function you want to set, “” means on , “” means off, press “←” to save the data and back to previous menu.

The station will snapshot after 5s while outdoor station is calling the indoor monitor under the snapshot is on.It also snapshot after 5s while the Front door station is calling, and the photo will be saved in the Device and upload to Center.

When key tone is on, there will be an accompanying sound when every time touch the screen.

When screen saver is on, the indoor monitor will be auto-screensaver.

Touch”Language”, interface will transform between CH-EN.

Select”Default Style”,change interface mode:

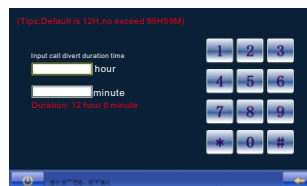

Divert on

提示：按“*”退格，按“#”确认
 Note：“*”for backspace,“#”for confirm

Touch “Divert on”, input the time, and press “#” to confirm. Directly click “#” without input the time, it will be default “Divert on” time 12 hours.

When there is a visitor, the system will transfer the call to the Guard Center under divert on.

Please note: when it is No-disturb status and “Divert on” enabled, it will cancel “NO-disturb” status.

Cancel divert on status: Click “Cancel divert on” and click confirm icon to cancel divert on

Volume

Touch “Volume”. There are 5 levels of Volume, press “+” to turn up the volume, press “-” to turn down the volume. Press ← to save the data and return to the previous menu.

Operation

No-disturb ON

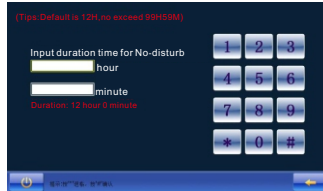

提示：按“*”退格，按“#”确认
Note: “*”for backspace, “#”for confirm

Touch “No-disturb ON”. Input the time, and press “#” to confirm. Directly click “#” “without input the time, it will be default No-disturb time 12 hours.

When there is a visitor, the door phone will not ring under No-disturb status.

Please note: when it is Divert on status and “No-disturb ON” enabled, it will cancel “Divert on” status.

Cancel No-disturb ON: The icon will become cancel No-disturb ON status after set successfully. User click “Cancel No-disturb ON” and confirm it to cancel No-disturb ON function.

Delay Settings

Touch “Delay Settings”.



提示：按“*”退格，按“#”确认
Note: “*”for backspace, “#”for confirm

Touch ring duration input box and input the time, press “#” to confirm.

Set the arm delay, upload delay and alarm duration with the same way.

Network settings: Only operated by engineers, can be set according to the community network layout.

Restore settings: Default setting, input password and click “#” to confirm. Be cautious ! Please restart after all settings are finished.

Call

Touch “Call” icon.

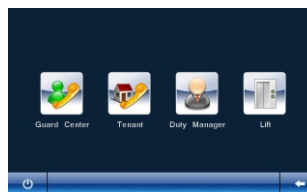

Guard Center : Call and talk with Guard Center, Calling sequence is Guard Station, back up Guard Station, Guard Center, back up Guard Center. If there is no answer, it will cut off automatically. If answer in the setting time, max conversation time is 120s. The tenant could delegate Guard Center to execute the service.

Tenant :Set the call format or call and talk with other tenants.

Touch “Tenant”, the screen shows:

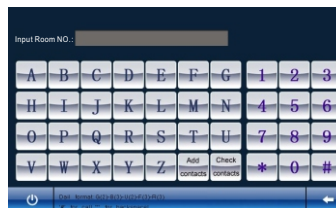

Dial Format Setting: Set the length of the No. Input “RULE”, and press “#” key to confirm.

Operation

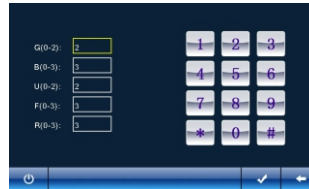

Input the numbers according to the tips, and press ✓ to save the data.

Call the Tenant: Input the Room No. according to the dial format you have set for the tenant. If no one answers, it will cut off automatically, If there is no answer, it will cut off automatically. If answer in the setting time, max conversation time is 120s.

You can add the Room No. of the tenant according to call format, and press “Add Contacts” to save.

You can check the numbers by touching “Check Contacts”.

Duty Manager: Click it and call to Guard Center.

Monitor

The station can monitor 30s. Touch “Monitor” to select “Gate Station”, “Sub Gate Station” or “Entrance Station” to monitor.

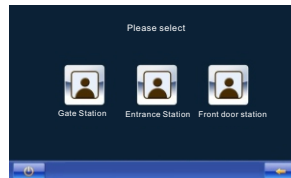

Press “←” or “→” to turn the pages if there are multiple monitor points , and touch ← to exit.

Messages

Touch "Messages".



Alarm Record

Touch "Alarm Record" to check the records, the screen will show:

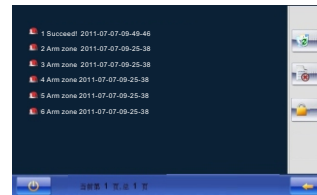

当前第1页，总1页：
Page 1, total 1

 : Delete all the records (except for the locked one)

 : Delete the selected records (locked records can't be deleted)

 /  : Lock/Unlock the selected records

 and  : Turn the pages when there are many records.

Operation

Voice Box

Touch "Voice Box" to check the records, the screen will show:

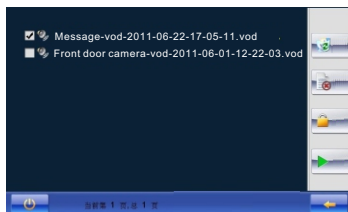

当前第1页，总1页：
Page 1, total 1

 : Delete all the voice records (except for the locked one)

 : Delete the selected voice records (the selected voice records would be yellow)

 /  : Lock/Unlock the selected voice record.

 : Play the selected voice records.

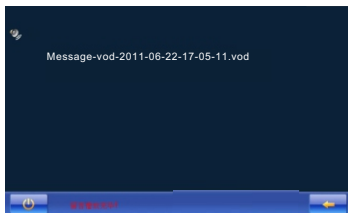

Press" ←" to the previous menu.

 and  : Turn the pages when there are many records.



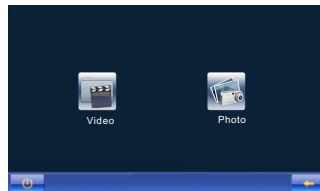

Snapshot

Touch "Snapshot" to check video and pictures, the screen will show :

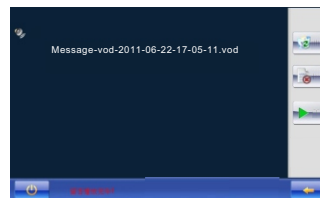

Video



-  : Delete all the videos (except for the locked one)
-  : Delete the selected videos (the selected one would be yellow)
-  : Play the selected videos.
-  /  : Turn the pages when there are many videos.

Photo

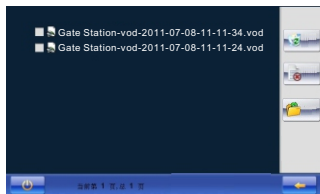

当前第1页，总1页：
Page 1, total 1

Operation



: Delete all the photos.



: Delete the selected photos. (the selected one would be yellow)



: View the selected photos.



:View the previous photo.



:View the next photo.





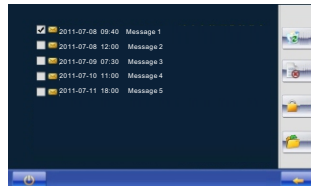

/ :Turn the pages when there are many photos.

Message





Touch “Message” to check the records, the screen will show while touched:

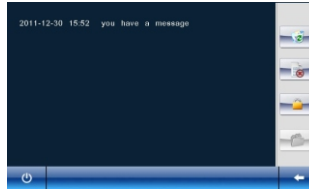

Operation

-  : Delete all the messages (except for the locked one)
-  : Delete the selected messages (the selected one would be yellow)
-  /  : Lock/unlock the selected messages.
-  : Read the selected message.



-  : Check the previous message.
-  : Check the next message.
-  and  : Turn the pages when there are many messages.

Note: When there is a new unread message, status indicator red light keep on, icon will be lighted.

Home/Outside

Express mode, one-button arm/disarm, it is convenient for users to control alarm zones.

On default style interface, click "Home" icon, then confirm it to arm all enabled alarm zones, "Home" icon become "Outside" icon. Touch "Outside" icon, input password and click "#" to confirm. If the password is correct, it will disarm all armed alarm zones.

On fashion style interface, click "Outside" icon, then confirm it to arm all enabled alarm zones. Touch "Home" icon input password and click "#" to confirm, it will disarm all armed alarm zones.

Service

All the service items will not work until the functions are activated.

Click “Service” icon, the screen will show:

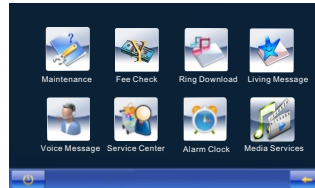

There are “Maintenance” “Fee check” “Ring download” “Living message” “Voice message” “Service Center” icons.

Maintenance: all the public system problems such as power supply problem, water supply problem, Kitchen problems etc .

Users can click “▲” and “▼” to select the service. Then click “√” to send the message to the guard center. If succeed, you will see a check box, click “OK” to exit.

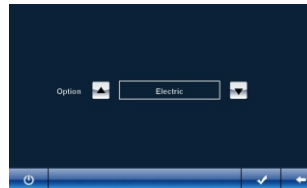

Fee Check: You can check the fee for water, electricity ,gas, management, drinking water and heating bills :

Click “▲” and “▼” to select the type of bill, and then click “√” to check the bill.

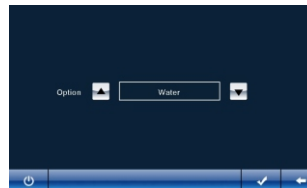

Operation



Ring download:

Download the ring tone from the guard center, please click the icon ,the screen will show:



 :Download the ring tone from the center to buffer and play.

 :To download the ring tone from the center to the door phone. You can set the ring tone downloaded in Ring.

 and  : Turn the pages when there are many ring tones.

Living message: Ask for handy service from the center (Only when the center offer this service):



Voice Message: Leave a message

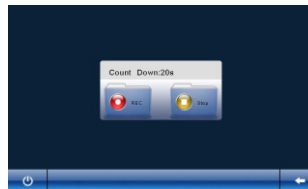

Click "REC" to leave a message. The voice message can last for 20s. Click "Stop" to stop recording..

Service Center: Users can call the service center to get services. To realize this function, need an IP telephone server and the telephone traffic platform.

Alarm Clock: Users can set time (Except weekend).

Smart Home

Touch “Smart Home”

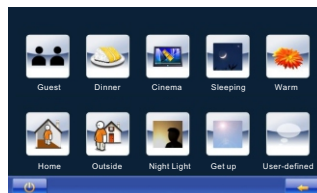

Select the scene you want by touching the icon, if prompt succeed, it means control all devices in this mode, as follows:

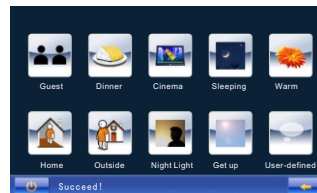

Being Called

When Gate Station or Entrance Station or Front Door Station is calling, the indoor monitor rings and the screen shows the situation at the entrance, when snapshot function is on, it will automatic take the photo at the entrance after 5s. Press “Intercom” to talk with the visitor, the conversation will last for 120s. Press “Snapshot” can take a photo at the entrance. Press “REC” can record the video at the entrance until the conversation end. Press “Silent” to shut down the rings. Press “Hang up” to end the call. Press “Unlock” while talking can release the door.

Alarm processing:

When the alarm is triggered, door phone will ring, status indicator red light is flashing, the screen will turn on, status indicator light of the triggered alarm zones become red, red words prompt the alarm zones are triggered.

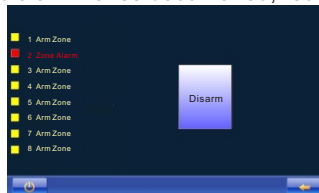

Tenant can check and cancel the alarm by door phones. Press “disarm” on the alarm interface, if it is express mode, disarm by express mode. If it is separate control zone, disarm by separate mode

Fire, Gas

If there is a alarm, it will alarm on-the-spot, and send the message to the Guard Center at the same time .

IR, Door Contact

After armed, the alarm will not be processed in delay time, then check, if there is a alarm, not disarm in 40s, it will alarm on-the-spot and send the information to Guard Center.

Zone5, Zone6

It will check after armed,if there is a alarm, it will alarm on-the-spot, not disarm in 40s, and send the information to Guard Center.

Zone7, Zone8

It will check after armed, if there is a alarm, it will alarm on-the-spot, and report to Guard Center.

Alarm

Press “” or external alarm button at any time, it will alarm and send the message Guard Center.

Operation

Lift

There are two ways for you to select. Press “” or press “Lift” under the “call” menu if the system is connecting with the lift

Description of Door Phones connected to each other

The system supports a Main door phone can link with 3 Sub door phones.

The No. of the main door phone must be 01, and the sub door phones are 02—04.

- 1.No-disturb on/off, Divert on/off, you can set ringing time on any one of them.
- 2.Any one of the door phones can call or monitor ,each door phone can process different alarm and arm independently.
- 3.All the phones can receive calls at one time. When one of them is talking, other three will be cut off automatically. The other three door phones can receive other calls at this time. In a word, three door phones can receive calls from three different ways(Such as Gate Station, Entrance Station, Guard Center).
- 4, Door phones can talk with each other: Input R1 (Represent main door phone) /R2(Second door phone) /R3 (Third door phone)/ R4(Fourth door phone) +”#”, can call the relevant door phone. For example, call 01 door phone, input “R1#”
5. The door phones which have snapshot function will take the photo and save it.

Others

1. Door phones Alarm Sensor connection: door phone can connect eight groups Alarm Sensor. Some alarm sensors are NC type(control touch spots are normally-closed when no alarm ,control touch spots are open when there is a alarm).Some are NO type(control touch spots are open when no alarm ,control touch spots are normally-closed when there is a alarm).When the alarm is NC type, should connect touch spots of sensors with -2.2K resistance in series (figure1).When the alarm is NO type , should connect touch spots of sensors with 2.2K resistance

in parallel (figure 2).When connecting resistance,should connect terminal of touch spots which is near sensor,it can make the sensor alarm when the sensor of door phone is forced to remove . Ports of each group sensor can connect with multiple same sensors to monitor multiple places,method is: NC type sensor alarm touch spots are connected in series (figure 3) , NO type sensor alarm touch spots are connected in parallel (figure 4). No matter how many sensors are connected in same group,just need one to be added resistance. Please note the total current of connected alarm sensors can not more than 400mA, you have to add another power supply if more than 400mA.

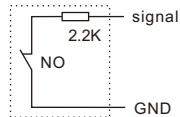

Figure 1

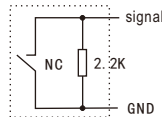

Figure 2

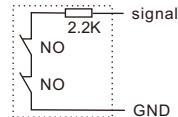

Figure 3

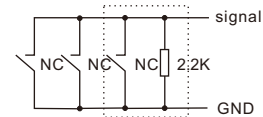

Figure 4

2. Door phone provide sensors with 2 groups 12V/0.5A voltage output ,one is non-control output, provide sensors with power source. One is control output, provide smoke sensor with power source. When there is a smoke alarm power will be cut off for 2s to reset the sensor.

3. When there is no power on the plug, all function cannot be used, add a storage battery for video power supply.

4. There is a socket for connecting external alarm input. Usually, if the alarm input and GND short circuit, it will send the alarm to Guard Center.

5. External calling bell can be connected with door phone, press it and “Dingdong” sound will ring out three times.

6. Tenant can arm/disarm the door phone via Guard Center.

7. Unlock by password or cards which are registered in Guard Center, it will disarm the armed zones.

8. When standby, press “” for more than 3s, then release, enter screen calibration function.

9. The icons in top right corner of monitor reflect its functional status, the icons will show if monitor network con-

Voltage Input	+18VDC
Humidity	45%~95%
LCD	7.0" color LCD
Sensitivity	≤20mV
Distortion	≤5%
Back Light	Build-in
Static Current	200mA (LCD Closed)
Working Current	300mA
S/N Ratio	≥70dBA
Operating Temperature	-10°C~+55°C
Visual Angle	50/70/70/70
Signal Input	MP4/H. 264/G. 711 Streaming Media
Power Output	≥500mW
Resolution	800×3 (RGB) ×480
Screen Size	diagonal 17.5cm(7.0")
Display Time	About 85-180s
Network Port	RJ45
Protocol	TCP/IP
Wiring Distance	Use a network switch or router in 100m, add a fib
Dimensions	285x170x28mm

Terminal mask		Description
Socket for external alarm and doorbell	External doorbell	External manual doorbell button
	GND	GND
	GND	GND
	External alarm	External alarm signal button
Socket for power input	+18V	+18VDC voltage input
	GND	GND
Socket for external sensor and alarm signal output	1	Fire sensor ON/OFF signal input
	2	Gas sensor ON/OFF signal input
	3	IR sensor ON/OFF signal input
	4	Door contact sensor ON/OFF signal input
	5~8	User-defined sensor ON/OFF signal input
	GND	GND
	IR	Door phone provide IR sensor with 12V/0.5A voltage output
	Fire	Door phone provide Fire sensor with 12V/0.5A voltage output
	Alarm output	External alarm

Trouble Shooting

Description	Check	Solution
Door Phone does not work	Check the power supply wire	Connect the wires correctly
Door Phone can not call & alarm to Guard Center	Check connection of the network wire. Check network parameters	Connect the network wire correctly and set network parameters correctly.
Door Phone does not ring when Gate Station call	Check connection of the network wire Check if the volume is the minimum or not Check if it is in no-disturb mode or not	Connect the network wire correctly, reset the ring tones and quit the No-disturb mode
Door Phone without monitor image	Check network parameters	Reset all the IP addresses
Detectors cannot alarm	Check if the alarm zones are enabled Check if alarm zone is armed or not Check the connection of the sensors.	Connect all the sensors correctly and reset door phones
Door Phones cannot call each other	Check if input correct number	Input the correct room numbers

Wiring

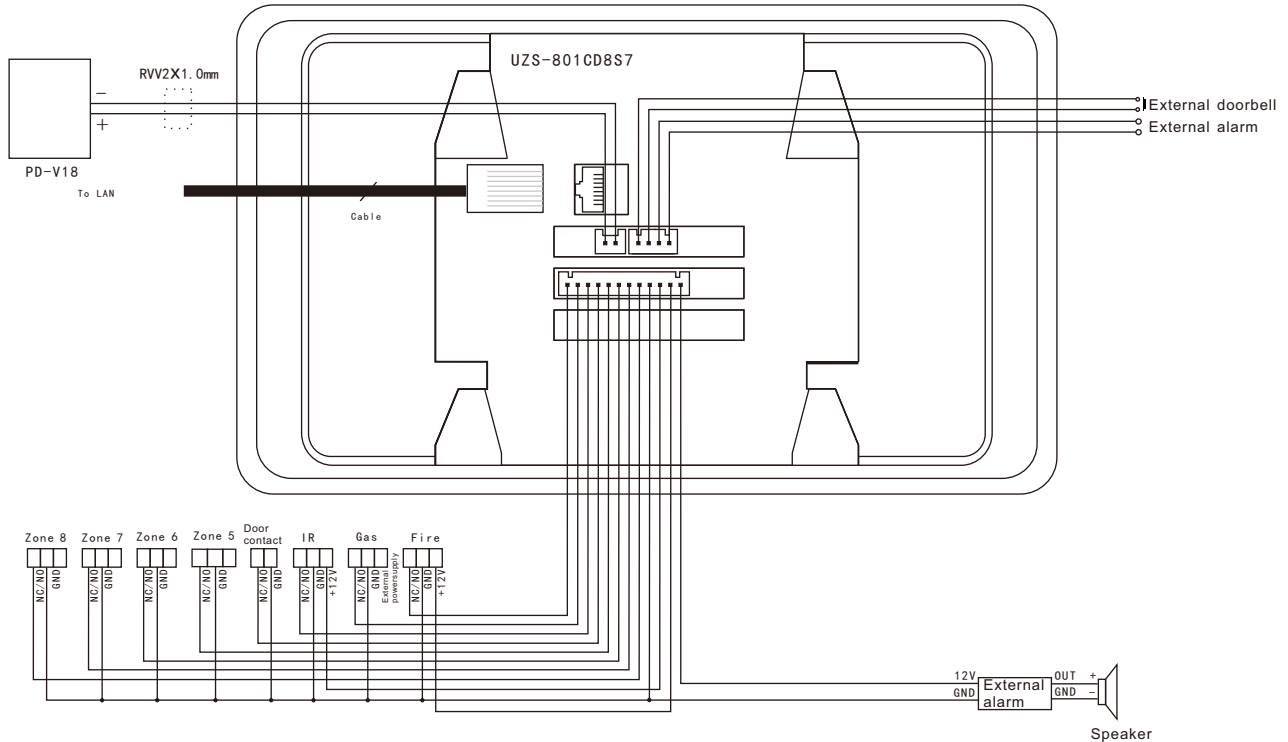

1. Defence Zone 1~4 can connect the short circuit or open circuit sensor, but could not be connected to the Speaker pulse signal probe as the switching signal time is more than 200 millisecond.
3. There are two ways of connection: NO mode and NC mode. Please connect correctly by reading the operation pages in this instruction.

Shenzhen WRT Intelligent Electrical Appliance Co.,Ltd

Add: WRT Industrial Base, Dafu Industrial Park, Guanguang Rd,
GuanLan Town, BaoAn District ,ShenZhen, China

Tel: +86 755 29576113

Fax: 86 755 29576023

Http:www.wrtsz.com